

UCrate® The Right Choice in Protecting Long & Narrow Products

Choose Quality, Speed and Service

UCrate® offers a highly durable, cost-effective option for protecting long, narrow products such as window blinds/rods, tubing, metal rods/extrusions, fragile instruments and glass products. It offers a cleaner, lighter-weight option than wood, is easier to load and is more stackable than tubes, and provides better impact resistance and scuff protection than corrugated...all leading to significant savings in labor, freight and storage.



UCrate® is a lightweight yet durable packaging option for protecting delicate items during shipping and handling. Its smooth laminated paperboard construction provides impact resistance, scuff protection and stackability.

See backside for more information.

VChannel®

A Flexible Shipping Option

A **VChannel®** can be easily converted into a UCrate®. Simply fold along the score and it is ready for use.

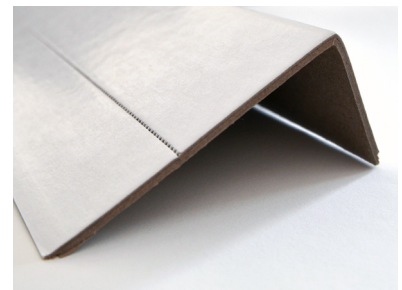

- Easily stack one on top of another
- Use space efficiently
- Optimize transport



The Right Choice in Protecting Long & Narrow Products

- Offers substantial beam strength while providing enough flexibility to provide shock absorption capabilities.
- Easy for workers to load and unload.
- Produced on state-of-the-art equipment to ensure fast turnaround and the highest-quality results.
- Backed by superior customer service with every order.
- Offered with a wide range of high-quality printing options: add your own logo or message.
- Additional custom interior packaging options available to meet your precise shipping and protection needs.
- Recyclable and environmentally friendly: a sustainable solution for your transport packaging needs.

Contact your local sales representative for samples.

Paper widths of up to 18 inches can be formed into virtually any combination of base sizes, leg sizes and leg lengths. When ordering UCrate®, please specify:

- 1 Leg size (height)
- 2 Base size (width): measured by the inside dimension
- 3 Wall caliper (thickness): available in calipers of 0.080 to 0.400 inches
- 4 Lengths: standard lengths available up to 300 inches; special-order lengths available

Note: You do not need to specify cover dimensions; cover will be designed to meet your base specifications.

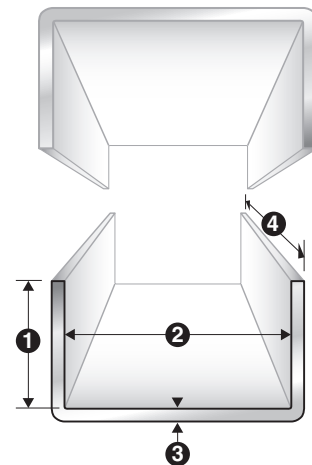

Read a UCrate® customer experience by scanning the QR code!



For more information contact your Laminations® account manager or visit laminationsonline.com.

East
7220 Schantz Road
Allentown, PA 18106-8804
Toll Free: 1-800-945-2626
610-706-0910
FAX: 610-706-0916

Southeast
1420 Vantage Way
Suite 100
Jacksonville, FL 32218
Toll Free: 1-800-720-0401
904-741-3150
FAX: 904-741-3155

Central - Headquarters
3010 East Venture Drive
P.O. Box 8033
Appleton, WI 54912-8033
Toll Free: 1-800-925-2626
920-831-0596
FAX: 920-831-0612

Northwest
9750 SW Hillman Court
Suite 100
Wilsonville, OR 97070
Toll Free: 1-800-685-2626
503-682-7195
FAX: 503-682-1723

West
12075 Cabernet Drive
Fontana, CA 92337-7703
Toll Free: 1-800-285-2626
951-727-8690
FAX: 951-361-2136